

5590 Hydraulic Pipe Cutter

Operation and Maintenance

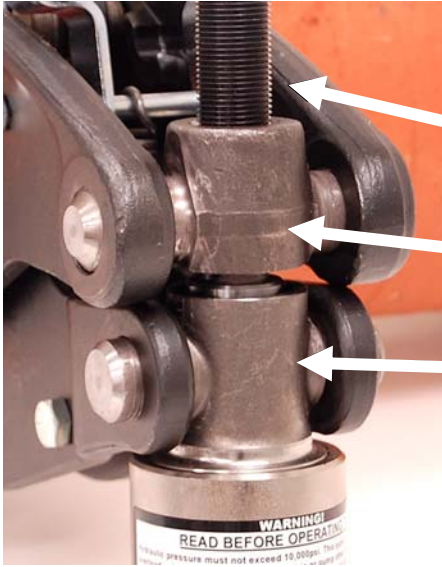

1. Turn adjusting screw until outer collar is at it's **lowest** limit of travel. Do this for **EACH** cut.

Adjusting Screw

Upper Trunnion

Lower Trunnion



2. Slide chain under pipe at location of cut.



3. Using hand ring, pull chain over pipe and under tie bolt, then up between jaws as tightly as possible. Allow chain to relax so nearest pin is engaged in slots under upper nose jaw. Chain then can be folded over on itself.

Be sure pins are actually seated in their respective slots before applying any pressure.

5590 Hydraulic Pipe Cutter

Operation and Maintenance



4. Front pin location (Nose Jaw)

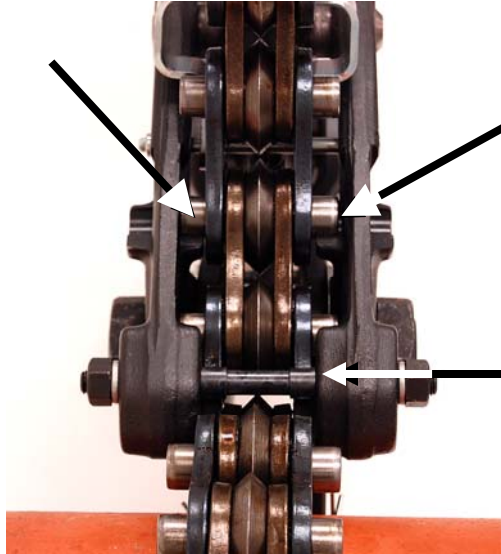

5. Rear pin location (Inner wall nest, both sides)

Tie Bolt

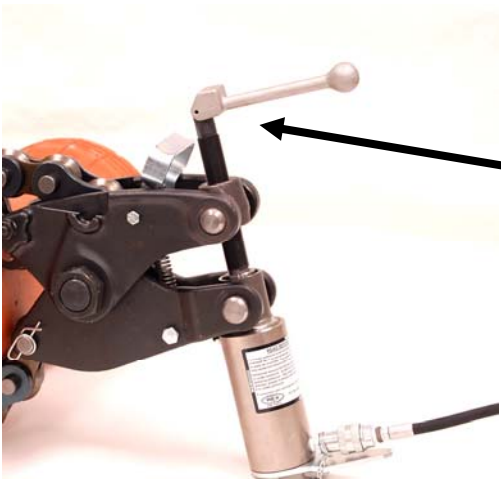

6. Take up remaining slack with adjusting screw.

5590 Hydraulic Pipe Cutter

Operation and Maintenance



7. Cutter wheels should touch pipe.



8. Attach hydraulic pump to cylinder. Remove dust cover from coupling, insert hydraulic hose end and turn threaded coupling sleeve until tight by hand.

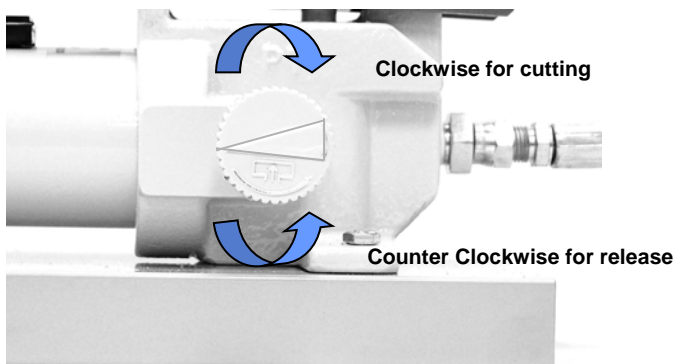

8. Turn valve clockwise on the pump until it is **HAND TIGHT**. **DO NOT USE A WRENCH**. Make strokes necessary to snap pipe. Release valve after cut to retract piston.

WARNING NOTES

WHEELER-REX HYDRAULIC CUTTERS

Before operating this product, read the operating instructions and be sure you understand this product's purpose, use, capability and limitations. Used within its capability for its intended purpose and with proper preventative maintenance, this product will give long reliable service.

Failure to read and follow operating instructions and these warning notes can result in serious injury to operator and/or bystanders.

1. Do **NOT** allow anyone other than a qualified operator to operate this product.
2. After engaging the chain and tightening the adjusting screw, check to be sure that the chain pins are fully seated in the pin grooves in the jaw.
3. Take the pump directly back from the ram perpendicular to the pipe being cut, with the hydraulic hose extended to its full **10 foot length**.
4. **Place the protective plastic sheet, supplied with the tool, over the work. The adjusting screw handle for the ram will fit through the hole in the plastic sheet.**
5. Before applying any hydraulic pressure, check to be sure that, excepting the operator:
 - a. No one is near or in line with either end of the pipe
 - b. No one is within 25 feet of the tool
6. The operator should be wearing proper safety items - hard hat and safety glasses
7. Each Wheeler-Rex pump has a built-in pressure overload valve set to factory specifications in accordance with the rated capacity of the tool. This valve is a safety feature intended to prevent the build up of hydraulic pressures above factory specifications.
DO NOT TAMPER WITH THIS VALVE FOR ANY REASON!!
8. Be sure there is a cutting wheel on every pin. Any pin not supported by a cutting wheel may be damaged when hydraulic pressure is applied. Do not allow wheels in upper or lower jaws to cross or contact each other.
9. If the pipe has not been cut by the time the overload valve starts to bypass excess pressure **STOP PUMPING AND RELEASE PRESSURE, NEVER APPROACH THE WORK WHILE THERE IS HYDRAULIC PRESSURE IN THE SYSTEM.**
Remove the tool from the work, and do the following:
 - a. Recheck the type, size and class of pipe being cut to be sure it is within the rated capacity of the tool.
 - b. Reinstall the tool following the instructions and safety precautions.
 - c. Repressurize the system.
 - d. If the pipe is still not cut by the time the overload valve starts to bypass, release pressure, remove the tool and place it with an authorized service center to be checked and, if necessary, adjusted or repaired.

DO NOT ATTEMPT TO ADJUST OR REPAIR THIS TOOL IN THE FIELD. SEE ENCLOSED LIST OF AUTHORIZED SERVICE CENTERS



Wheeler-Rex * 3744 Jefferson Road * Ashtabula, OH 44004
Tel: 800-321-7950 * Fax: 440-992-2925 * www.wheelerrex.com



Hydraulic Pipe Cutters

- When cutting in a line, remove excess mud, scale and rust from surface of pipe where chain wheels will make contact. This will allow wheels to contact solid pipe for maximum penetration. An excellent tool for this is the Wheeler-Rex Pipe Scraper Model 1300 or Model 1350.
- Keep the upper jaw tie bolt tightened at all times! Operation of the cutter with this bolt loose can result in serious damage.
- Do not use brake fluid in the hydraulic system under any circumstance! It will irreparably damage the packings.
- The pump oil tank should be kept at least 3/4 full.
- Repairs to the hydraulic system should be made only by qualified personnel in accordance with factory specifications.
- Transportation charges must be prepaid on all units sent to service stations or to the factory for repair. If factory defect is disclosed, the repaired unit will be returned to you prepaid.
- Manufacturers liability and warranties are voided if anything other than factory authorized parts are used.
- We suggest once you have established which chain pin must be engaged for a specific pipe size, that you clearly mark this pin for easy recognition (a dab of paint will work). This will facilitate quick, sure, efficient operation for all cuts of the same pipe size.
- We recommend pumping the piston all the way to the top of its stroke after each use. This will lubricate the cylinder and remove any water that has entered the cylinder. This is especially after the unit has been in used water or under extremely dirty conditions. Release pressure so that the piston returns to a completely closed position. If necessary, apply hand pressure to return the piston back to its closed position.

CAUTION !!!

**Avoid standing close to either end of the pipe!
The great amount of pressure exerted by the cutter may
cause the cut sections to pop-off in opposite directions!**

CHAIN CHART	
PART NO.	PIPE SIZE
3824	12"
382415	15"
382418	18"
382424	24"

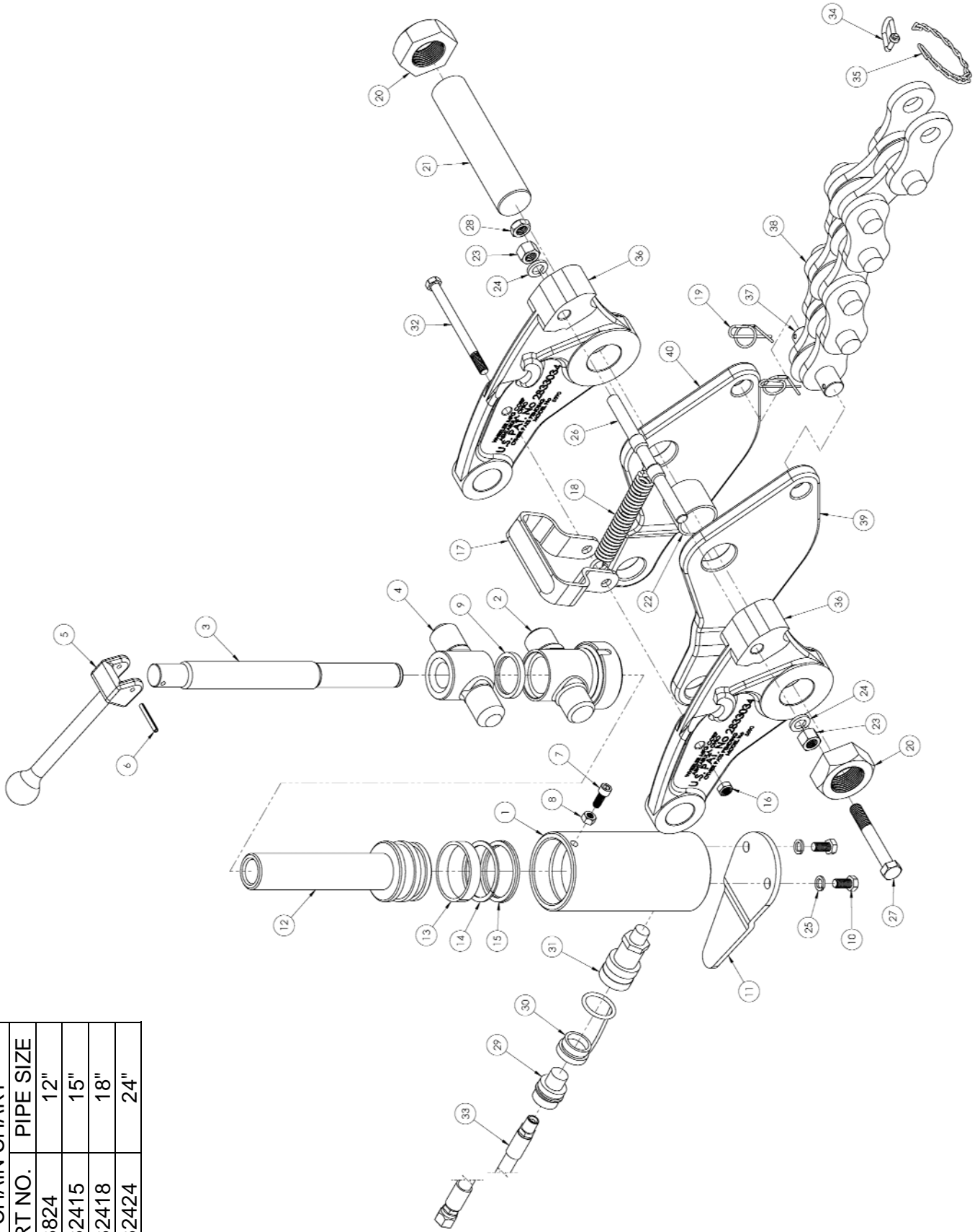

5590 HYDRAULIC PIPE CUTTER

Item	Part No	Description	Qty
1	5532	CYLINDER	1
2	3842	TRUNION MACHINED	1
3	3848	PISTON ROD	1
4	3841	UPPER TRUNION	1
5	3855	HANDLE (MACHINING)	1
6	275862	3/16" DIA x 1 1/2" ROLL PIN	1
7	3537	5/16"-18 x 3/4" SHCS	1
8	126	5/16"- 18 HEX NUT	1
9	3883	RING-PISTON WIPER	1
10	5507	3/8"-16 x 3/4" HHCS	2
11	5508	KICK PLATE	1
12	220728	PISTON	1
13	275772	BEARING RING	1
14	275771	BACKUP RING	1
15	275770	SEAL	1
16	105	3/8"-16 ESNA NUT	1
17	3851	HANDLE	1
18	3878	RETURN SPRING	1
19	3908	HAIR PIN CLIP	2
20	3893	JAW PIVOT NUT 1 1/2"- 12	2
21	5592	JAW PIVOT	1
22	5584	JAW SPACER	1
23	3866	1/2"-13 HEX NUT	2
24	3879	1/2" SPLIT LOCK WASHER	2
25	7179	3/8" SPLIT LOCK WASHER	2
26	223071	TIE ROD	1
27	5527	1/2-13 x 3 1/2" LONG HHCS	1
28	3828	1/2"-13 ESNA NUT	1
29	5710	COUPLER, HOSE HALF	1
30	5705	DUST CAP	1
31	5750	COUPLER-RAM HALF	1
32	5595	SPRING BOLT	1
33	3918	HOSE	1
34	5418	COLD SHUT	1
35	5408	CHAIN HANDLE	1
36	5510	UPPER JAW	2
37	5605	CHAIN TO JAW PIN	1
38	SEE CHART	CHAIN	1
39	5521	LOWER LEFT JAW	1
40	5520	LOWER RIGHT JAW	1

Hydraulic Hand Pump

Wheeler-Rex Pump Model Numbers:

Model 1930 for 5590 10,000psi
 Model 1830 for 3890 5,700psi
 Model 1630 for 2990 9,000psi

HYDRAULIC HAND PUMP

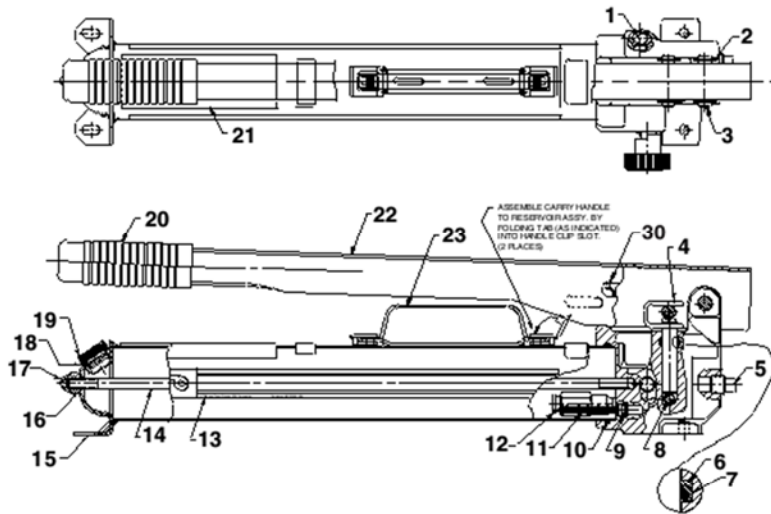

Hydraulic Hand Pump PFF-WMC

Item	Description	Wheeler #	Spx #	Qty
1	Decal	276182	215907	1
2	Retaining Ring	275795	211743	4
3	Pin	275583	211742	2
4	Piston Assembly	220843	211468	1
5	Pressure Plug	277074	11127	1
*6	Backup Washer	276154	213987	1
*7	O-Ring viton	276155	11445	1
8	Steel Ball	276157	10378	1
*9	O-Ring viton	276171	18973	1
*10	O-Ring viton	276174	213209	1
11	Filter Plug	276172	215075	1
12	Relief Valve (Red)	1857	21278-52	1
	Relief Valve (Blue)	1657	21278-86	1
	Relief Valve (Black)	1957	21278-80	1
14	Tie Rod	276178	252502	1
15	Reservoir Assembly	276176	351367	1
*16	Viton O-Ring	277075	11439	1
17	Acorn Nut	277076	10842	1
18	Viton O-Ring	277077	253597	1
19	Filler Cap	277078	351245	1
20	Handle Grip	580	580	1
22	Handle (Blue)	276149	64117BL2	1
	Handle (Red)	276151	64117RE3	1
	Handle (Black)	276150	64117BK2	1
23	Carry Handle		58048	1
25	Hydraulic Hose	3915		1

END VIEW AND SECTION A-A

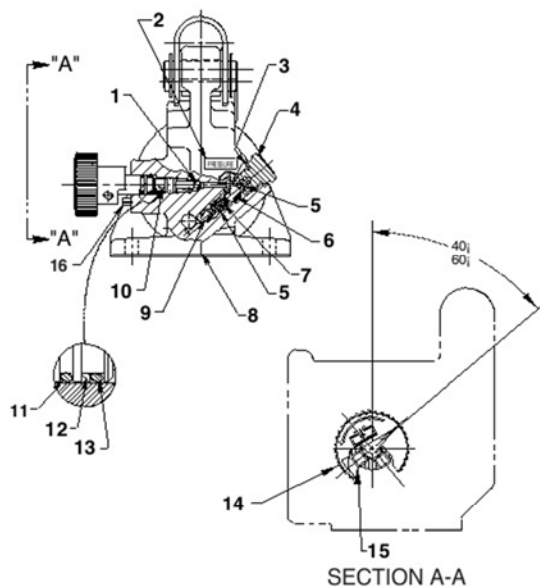

End View Parts

Item	Description	Wheeler #	Spx #	Qty
1	Ball	203197	12223	1
2	Decal	N/A		1
3	Copper Washer	276162	14874	1
4	Valve Screw	277079	351952	1
5	Compression Spring	276163	10444	2
6	Steel Ball	276157	10378	1
7	Compression Spring	276165	211797	1
8	Pump Body	276167	61295	1
9	Steel Ball	276166	10375	1
10	Release Valve Screw	275585	350185	1
11	O-Ring		14763	1
*12	Backup Washer	276161	15085	1
*13	Viton O-Ring	276160	18974	1
14	Release Valve Knob	277080	351087	1
15	Set Screw	276165	10556	1 or 2
16	Slotted Spring Screw	277081	10714	1

* Included in 1856 Repair Kit