

# TEST PLUGS (FRONTS)

## SPECIFICATIONS

Stemar Test plugs are made of natural rubber with specialized end plates for testing and pressure monitoring applications.

Common applications include pipeline acceptance tests, water tests, sewer air tests, water block & release, and leak location.

Stemar maintains a supply of both rental and new plugs up to 96" in diameter

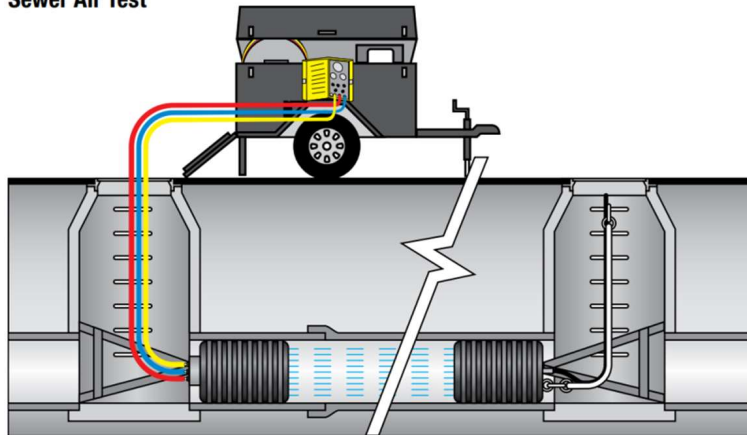
**Sewer Air Test**

Plug Size	Stemar RC#	Mfg. Code	Usage Range (Pipe ID)	Inflation Pressure	Maximum Test/Back Pressure	Product Weight	Deflated Length	Deflated Diameter	Bypass Diameter (F-NPT)	Eye Bolts
4"-6"	2444	C	3.75"-6.25"	35 PSI	17 PSI	2.5 LBS.	10.75"	3.46"	3/4"	(1) FRONT, 1/4"
4"-6"	2200	L	3.5"-6.25"	30 PSI	15 PSI	2 LBS.	9.5"	3.5"	1/4" & 1/4"	(1) FRONT, <i>molded rubber</i>
6"-10"	2210	L	5.25"-10.25"	30 PSI	15 PSI	15 LBS.	19.7"	5.25"	1/2" & 1/4"	(1) FRONT & BACK, 1/4"
6"-12"	2106	C	5.5"-12.25"	45 PSI	**15 PSI	8 LBS.	25"	5.25"	1/2" & 1/4"	(2) FRONT & BACK, 1/4"
8"-12"	2211	L	7.25"-12.25"	25 PSI	15 PSI	27 LBS.	20"	6.25"	3/4" & 1/4"	(1) FRONT & BACK, 1/4"
8"-16"	2271	C	7"-16.25"	45 PSI	**15 PSI	15 LBS.	28"	7"	1/2" & 1/4"	(2) FRONT/BACK, 1/4"
12"-18"	2212	L	11"-18.25"	25 PSI	15 PSI	48 LBS.	28"	10.5"	3/4" & 1/4"	(3) FRONT & BACK, 1/4"
12"-18"	2233	C	11"-18.25"	25 PSI	**15 PSI	50 LBS.	28"	10.5"	1/2" & 1/4"	(2) FRONT & BACK, 1/4"
12"-24"	2272	L	11"-24.25"	25 PSI	15 PSI	76 LBS.	41"	10.5"	3/4" & 1/4"	(3) FRONT & BACK 3/8"
12"-24"	2238	C	11"-24.25"	30 PSI	**13 PSI	41 LBS.	40"	11"	1/2" & 1/4"	(2) FRONT & BACK, 1/4"
15"-30"	2213	C	14.5"-30.5"	25 PSI	**11 PSI	45 LBS.	51"	14"	1/2" & 1/4"	(2) FRONT & BACK 3/8"
15"-32"	2274	C	15"-32"	25 PSI	**12.2 PSI	80 LBS.	48"	14.3"	1/2" & 1/4"	(2) FRONT & BACK 3/4"
20"-40"	2252	C	19"-40"	22 PSI	**8.7 PSI	96 LBS.	46.25"	18.5"	1/2" & 1/4"	(2) FRONT & BACK 1/2"
24"-48"	2254	C	20.5"-50"	22 PSI	**10.1 PSI	125 LBS.	74.5"	20"	1/2" & 1/4"	(2) FRONT & BACK 3/4"
24"-60"	2273	C	20.5"-60.5"	22 PSI	**6 PSI	164 LBS.	88"	20"	1/2" & 1/4"	(2) FRONT & BACK 3/4"

**\*\*CONSULT PRESSURE TABLE BELOW**

**ALWAYS BLOCK PLUGS WHEN CONDUCTING AIR OR WATER TESTS**

### TEST PLUGS, BACK PRESSURE TABLE(PSI): 1 PSI = 2.31 FT OF HEAD

Plug Size	Stemar RC#	PIPE INSIDE DIAMETER																		
		6"	8"	10"	12"	16"	18"	20"	24"	30"	36"	40"	42"	48"	54"	60"	66"	72"	84"	96"
6"-12"	2106	26	23	22	15	-	-	-	-	-	-	-	-	-	-	-	-	-	-	-
8"-16"	2271	-	29	27	25	15	-	-	-	-	-	-	-	-	-	-	-	-	-	-
12"-18"	2233	-	-	-	25	22	15	-	-	-	-	-	-	-	-	-	-	-	-	-
12"-24"	2238	-	-	-	27	25	22	19	15	-	-	-	-	-	-	-	-	-	-	-
15"-30"	2213	-	-	-	-	17	13	13	11	11	-	-	-	-	-	-	-	-	-	-
15"-32"	2274	-	-	-	-	18.6	17.6	16.6	15.4	12.2	-	-	-	-	-	-	-	-	-	-
20"-40"	2252	-	-	-	-	-	-	13.6	12.5	11.2	10.2	-	-	-	-	-	-	-	-	-
24"-48"	2254	-	-	-	-	-	-	-	15.2	13.9	12.8	11.4	10.1	-	-	-	-	-	-	-
24"-60"	2273	-	-	-	-	-	-	-	15.6	15.2	14.8	14	14	12.6	9.6	6	-	-	-	-